

GENERAL PURPOSE VALVES



Series 30 >> Model 33

3-Way Normally Closed Valve – Piped Exhaust

Complete range of valves particularly suitable when cost and size are major factors. The bodies are constructed of brass (stainless steel is optional). Air, water, and other fluids compatible with standard Buna seals. Hot water, steam, gasoline, and many oils require special seal materials.

- Brass body with stainless steel internal construction.
- A smaller, cost effective alternative to any industry standard.

OPERATING CONDITIONS

Media: Air, water, and other fluids compatible with standard Buna seals. Hot water, steam, gasoline, and many oils require special seal materials. (Series 30 pressure ratings may change due to the viscosity of the liquid.)*

Valve Temperature Range: Standard Valves - 0°F (-18°C) to 104°F (40°C) ambient; 0°F (-18°C) to 150°F (65°C) media. Optional Valves - can tolerate much higher or much lower ambient and media temperatures.*

Maximum Operating Pressure Differentials: See table on proceeding page.

Burst Pressure: 5000 PSI

Leakage: Bubble tight for standard valves.

Vacuum: To 5 Microns*

ELECTRICAL CHARACTERISTICS

Coil Voltage: 6.0 to 650V AC 60 HZ. and 5.2 to 560V AC 50 HZ. – 2.0 to 240V DC

Nominal Power: AC – 8.0 Watts, DC – 8.0 Watts

Coil Construction: Non-molded Class A, Molded and potted Class F. (Class H optional)

Typical Response Time on Air: 4 - 16 Milliseconds

Operating Speed: Up to 600 CPM

Duty Cycle: Continuous

MECHANICAL CHARACTERISTICS

Body: Brass (Std.) or Stainless Steel (Opt.)

Internal Components: Stainless Steel

Elastomers: Nitrile (Buna) (Std.). Many other elastomers available.*

Orifice Diameter: See table on proceeding page.

Porting: Standard 1/8" NPT (other ports available).*

Housing: Grommet and 1/2" NPT conduit - many options available.*

Listings: Most valves are UL and CSA listed.*

Life Expectancy: Millions of cycles, depending on application, lubrication, etc.

Valve Weight: Grommet Valve: 0.75 lb Conduit Valve: 0.81 lb

Repair Packs: See table on proceeding page.

Options: Alternate Port Locations, Metering, Manual Override, Alternate Elastomers, Spade Terminal Coil

* Consult representative or factory for options and specifications.

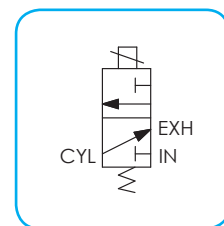
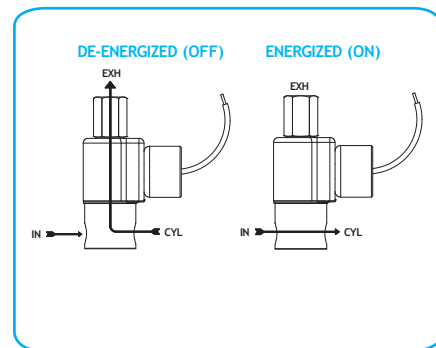

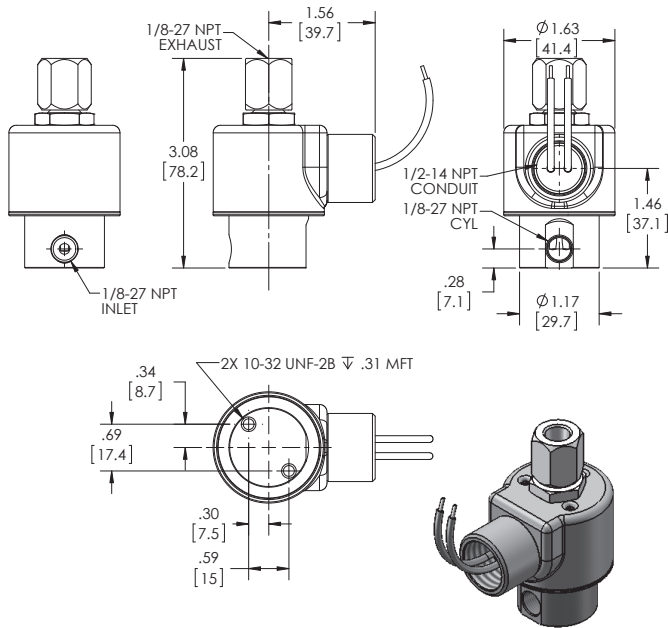

**SERIES 30
MODEL 33
3WNC
PIPED EXHAUST
CONDUIT CONNECTION**

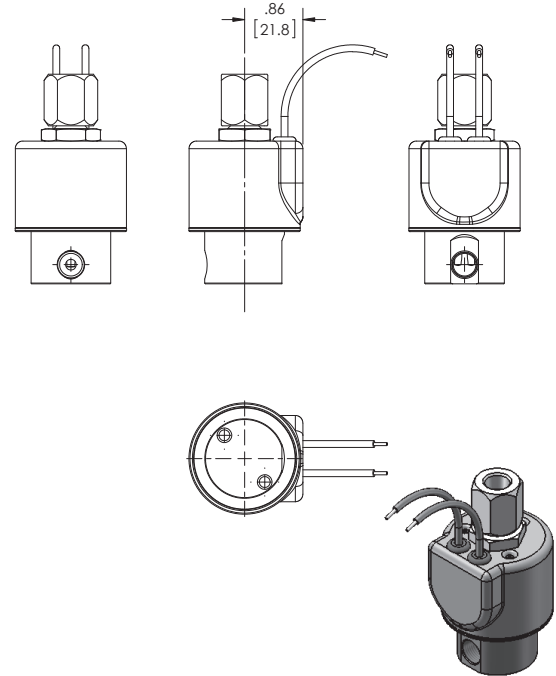

**SERIES 30
MODEL 33
3WNC
PIPED EXHAUST
GROMMET HOUSING WITH LEADS**

VALVE SPECIFICATIONS

MAX. OPER. PRESS. DIFF.		ORIFICE SIZE		CV FACTOR		VALVE NUMBER	
AC	DC	N.C.	N.O.	N.C.	N.O.	GROMMET HOUSING 1/8 NPT PORTS	CONDUIT HOUSING 1/8 NPT PORTS
300	300	1/32	1/32	.024	.024	33GG5XGV	33GG5XCV
175	175	3/64	1/16	.052	.095	33HJ5XGV	33HJ5XCV
125	125	1/16	1/16	.095	.095	33JJ5XGV	33JJ5XCV
75	75	3/32	3/32	.160	.160	33KK5XGV	33KK5XCV
50	50	1/8	3/32	.275	.160	33NK5XGV	33NK5XCV

WHEN ORDERING VALVES OR REPAIR PACKS ADD VOLTAGE AND FREQUENCY TO COMPLETE VALVE NUMBER. EXAMPLES: VALVE (33JJ5XCV-120/60) REPAIR PACK (K33JJX-AC).