



Series 70 >> Model 72B

Very Large Orifice, Non-Piloted – 2-Way Normally Closed

Super valves that have ratings that formerly required valves of much greater size. They are higher flow at low pressures and have quick media fill or dump for air, inert gases, and oil.

- Largest direct acting (non-piloted) valve we manufacture.
- Large orifice.
- High flow at low pressures.
- Gravity feed lubrication with quick media fill or dump.

OPERATING CONDITIONS

Media: Air, inert gases, and oil. (Series 70 pressure ratings may change due to the viscosity of the liquid.)*

Valve Temperature Range: Standard Valves - 0°F (-18°C) to 104°F (40°C) ambient; 0°F (-18°C) to 150°F (65°C) media. Optional Valves - can tolerate much higher or much lower ambient and media temperatures.*

Maximum Operating Pressure Differentials: See table on proceeding page.

Burst Pressure: 500 PSI

Leakage: Bubble tight for standard valves.

Vacuum: To 5 Microns*

ELECTRICAL CHARACTERISTICS

Coil Voltage: 12 to 1150V AC 60 HZ. and 11 to 1035V AC 50 HZ. – 2.5 to 220V DC

Nominal Power: AC – 18.0 Watts DC – 16.0 Watts

Coil Construction: Non-molded Class A (Std.), Molded and Potted Class F, Class H (Opt.)

Typical Response Time on Air: 6-12 milliseconds to open, 12-28 milliseconds to close.

Operating Speed: Up to 350 CPM

Duty Cycle: Continuous

MECHANICAL CHARACTERISTICS

Body: Aluminum anodized, corrosion resistant

Internal Components: Stainless Steel

Elastomers: FKM (Std.). Many other elastomers available.*

Orifice Diameter: See table on proceeding page.

Porting: 1/2" NPT

Housing: Grommet and 1/2" NPT conduit - many options available.*

Listings: Most valves are UL and CSA listed.*

Life Expectancy: Millions of cycles, depending on application, lubrication, etc.

Valve Weight: 1.88 lbs

Repair Packs: See table on proceeding page.

Options: Alternate Elastomers and Stainless Steel Body*

* Consult representative or factory for options and specifications.

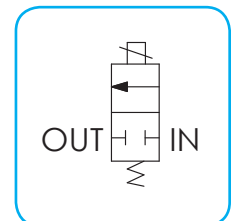
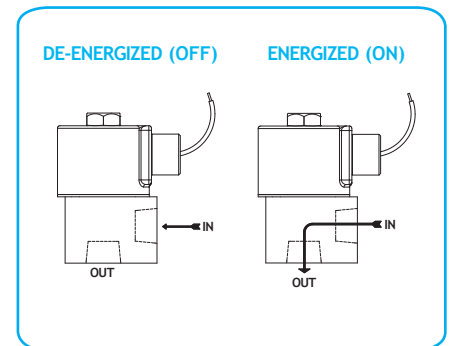

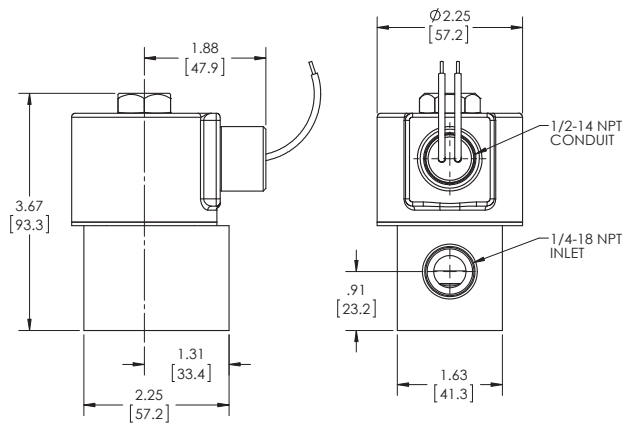

**SERIES 70
MODEL 72B 1/2-14 NPT
2WNC
CONDUIT CONNECTION**

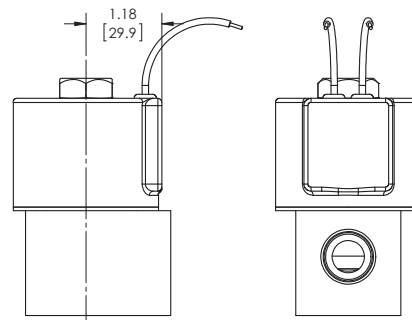

**SERIES 70
MODEL 72B 3/8-18 NPT
2WNC
GROMMET HOUSING WITH LEADS**

VALVE SPECIFICATIONS

MAX. OPER. PRESS. DIFF.		ORIFICE SIZE	CV FACTOR	VALVE NUMBER	CONDUIT HOUSING
AC	DC	N.C.	N.C.	GROMMET HOUSING 1/2" NPT PORTS	1/2" NPT PORTS
15	15	1/2	2.92	72B11DGV	72B11DCV

WHEN ORDERING VALVES OR REPAIR PACKS ADD VOLTAGE AND FREQUENCY TO COMPLETE VALVE NUMBER. EXAMPLES: VALVE (72B11DGV-120/60) REPAIR PACK (K72BD-AC)