

LOW LOW WATT VALVES



Series 50 LLW >> Model LLW52

Low, Low Wattage – 2-Way Normally Closed Valve

General purpose safety valve for pneumatic applications. The versatility of these valves is increased to include the handling of hot air, refrigerants and many other media, by the use of different seals. Air and other gases compatible with standard Buna seals.

- General purpose valve with reduced power consumption.
- Increased versatility.
- For pneumatic application.
- Increased to handle hot air, refrigerants and other gases.

OPERATING CONDITIONS

Media: Air and other gases compatible with standard Buna seals.

Valve Temperature Range: Standard Valves - 0°F (-18°C) to 140°F (60°C) ambient; 0°F (-18°C) to 150°F (65°C) media. Optional Valves - can tolerate much higher or much lower ambient and media temperatures.*

Maximum Operating Pressure Differentials: See table on proceeding page.

Burst Pressure: 5000 PSI

Leakage: Bubble tight for standard valves.

Vacuum: To 5 Microns*

ELECTRICAL CHARACTERISTICS

Coil Voltage: 6.0 to 120V DC

Nominal Power: DC – .65 Watts

Coil Construction: Molded and potted Class F. (Class H optional)

Typical Response Time on Air: 4 - 16 Milliseconds

Operating Speed: Up to 600 CPM

Duty Cycle: Continuous

MECHANICAL CHARACTERISTICS

Body: Stainless Steel (Std.), Brass (Opt.) or Aluminum (Opt.)

Internal Components: Stainless Steel

Elastomers: Nitrile (Buna) (Std.). Many other elastomers available.*

Orifice Diameter: See table on proceeding page.

Porting: 1/8" NPT (Std.)

Housing: Grommet and 1/2" NPT conduit - many options available.*

Listings: Most valves are UL and CSA listed – consult factory.

Life Expectancy: Millions of cycles, depending on application, lubrication, etc.

Valve Weight: Grommet Valve: 0.38 lbs, Conduit Valve: 0.44 lbs

Repair Packs: See table on proceeding page.

Options: Alternate Port Locations, Metering and Alternate Elastomers*

* Consult representative or factory for options and specifications.

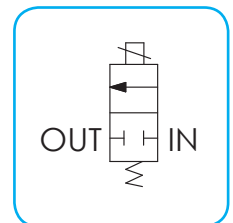
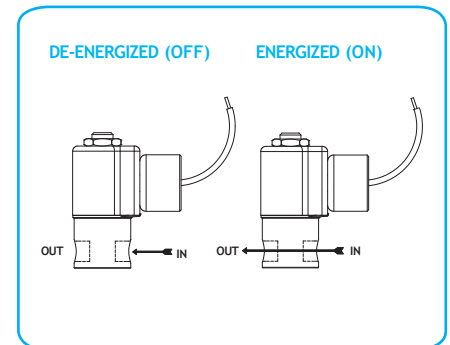

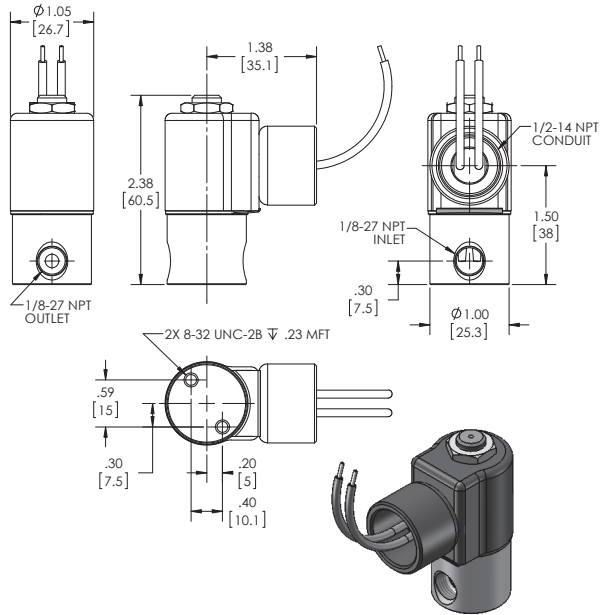

**SERIES 50 LLW
MODEL LLW52
2WNC
CONDUIT CONNECTION**

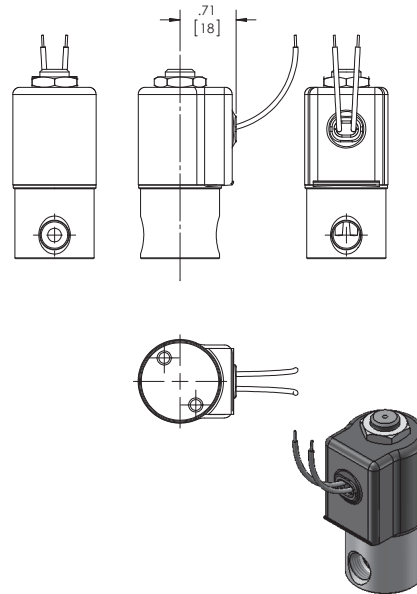

**SERIES 50 LLW
MODEL LLW52
2WNC
GROMMET HOUSING WITH LEADS**

VALVE SPECIFICATIONS

MAX. OPER.
PRESS. DIFF.

GAS	ORIFICE SIZE	CV FACTOR	VALVE NUMBER	
DC	N.C.	N.C.	GROMMET 1/8" NPT	CONDUIT 1/8" NPT
120	1/32	.022	LLW53GG8DGM	LLW53GG8DCM

WHEN ORDERING VALVES OR REPAIR PACKS ADD VOLTAGE AND FREQUENCY TO COMPLETE VALVE NUMBER. EXAMPLES: VALVE (LLW52G8DGM-12/DC) REPAIR PACK (KLLW52G-DC)