

# LOW WATT VALVES



## Series 50 LW >> Model LW53

### Low Wattage —3-Way Normally Closed (piped exhaust)

General purpose for pneumatic and hydraulic applications. The versatility of these valves is increased to include the handling of hot air, hot water, refrigerants and many other media, by the use of different seals. Air and other fluids compatible with standard Buna seals. Hot water, steam, gasoline, oils, some hydraulic fluids, and many media require special seal materials.

- General purpose valve with reduced power consumption.
- Increased versatility.
- For pneumatic and hydraulic application.

## OPERATING CONDITIONS

**Media:** Air and other fluids compatible with standard Buna seals. Hot water, steam, gasoline, oils, some hydraulic fluids, and many media require special seal materials. (Series 50 pressure ratings may change due to the viscosity of the liquid.)\*

**Valve Temperature Range:** Standard Valves - 0°F (-18°C) to 140°F (60°C) ambient; 0°F (-18°C) to 150°F (65°C) media. Optional Valves - can tolerate much higher or much lower ambient and media temperatures.\*

**Maximum Operating Pressure Differentials:** See table on proceeding page.

**Burst Pressure:** 5000 PSI

**Leakage:** Bubble tight for standard valves.

**Vacuum:** To 5 Microns\*

## ELECTRICAL CHARACTERISTICS

**Coil Voltage:** 12 to 370V AC 60 HZ. and 10.5 to 345V AC 50 HZ. — 6.0 to 120V DC

**Nominal Power:** AC — 2.5 Watts DC — 2.5 Watts

**Coil Construction:** Molded and potted Class F. (Class H optional)

**Typical Response Time on Air:** 4 - 16 Milliseconds

**Operating Speed:** Up to 600 CPM

**Duty Cycle:** Continuous

## MECHANICAL CHARACTERISTICS

**Body:** Stainless Steel (Std.), Brass (Opt.) or Aluminum (Opt.)

**Internal Components:** Stainless Steel

**Elastomers:** Nitrile (Buna) (Std.). Many other elastomers available.\*

**Orifice Diameter:** See table on proceeding page.

**Porting:** 1/8" NPT (Std.)

**Housing:** Grommet and 1/2" NPT conduit - many options available.\*

**Listings:** Most valves are UL and CSA listed — consult factory.

**Life Expectancy:** Millions of cycles, depending on application, lubrication, etc.

**Valve Weight:** Grommet Valve: 0.38 lbs, Conduit Valve: 0.44 lbs

**Repair Packs:** See table on proceeding page.

**Options:** Alternate Port Locations, Metering and Alternate Elastomers\*

\* Consult representative or factory for options and specifications.

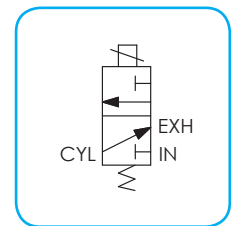
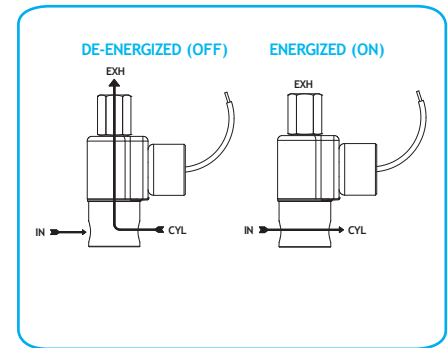

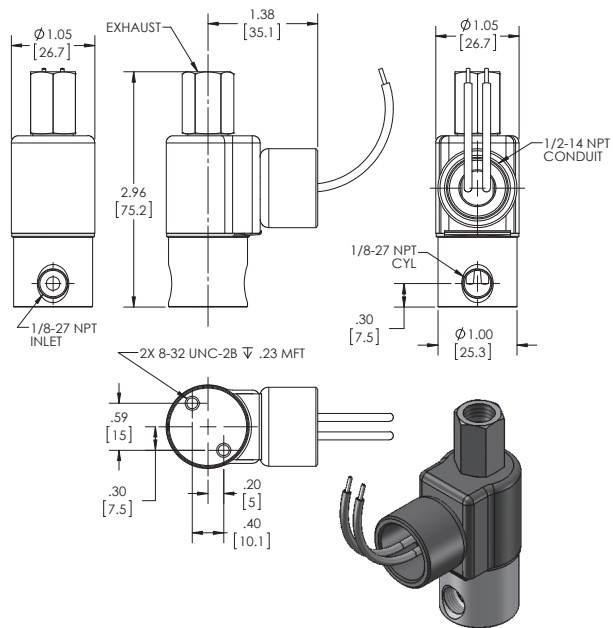

**SERIES 50 LW  
MODEL LW53  
3WNC PIPED EXHAUST  
CONDUIT CONNECTION**

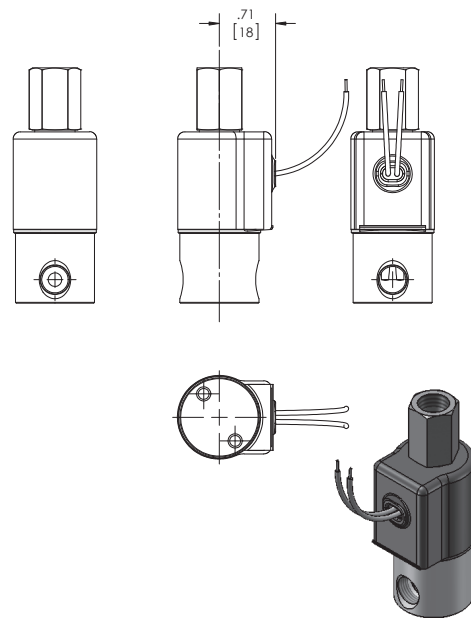

**SERIES 50 LW  
MODEL LW53  
3WNC PIPED EXHAUST  
GROMMET HOUSING WITH LEADS**

## VALVE SPECIFICATIONS

MAX. OPER. PRESS. DIFF.		MAX. OPER. PRESS. DIFF.		ORIFICE SIZE		CV FACTOR		VALVE NUMBER	
GAS		LIQUID		N.C.		N.O.		GROMMET 1/8" NPT	
AC	DC	AC	DC	N.C.	N.O.	N.C.	N.O.	GROMMET 1/8" NPT	CONDUIT 1/8" NPT
215	135	215	135	1/32	1/32	.022	.022	LW53GG8XGM	LW53GG8XCM
215	120	120	65	1/32	3/64	.022	.048	LW53GH8XGM	LW53GH8XCM
135	50	40	30	1/32	1/16	.022	.075	LW53GJ8XGM	LW53GJ8XCM
70	35	30	20	1/32	5/64	.022	.134	LW53GV8XGM	LW53GV8XCM
55	30	25	15	1/32	3/32	.022	.156	LW53GK8XGM	LW53GK8XCM
120	70	120	65	3/64	3/64	.055	.048	LW53HH8XGM	LW53HH8XCM
120	50	40	30	3/64	1/16	.055	.075	LW53HJ8XGM	LW53HJ8XCM
70	35	30	20	3/64	5/64	.055	.134	LW53HV8XGM	LW53HV8XCM
55	30	25	15	3/64	3/32	.055	.156	LW53HK8XGM	LW53HK8XCM
85	40	40	30	1/16	1/16	.075	.075	LW53JJ8XGM	LW53JJ8XCM
70	35	30	20	1/16	5/64	.075	.134	LW53JV8XGM	LW53JV8XCM
55	30	25	15	1/16	3/32	.075	.156	LW53JK8XGM	LW53JK8XCM
50	30	30	20	5/64	5/64	.134	.134	LW53VV8XGM	LW53VV8XCM
50	30	25	15	5/64	3/32	.134	.156	LW53VK8XGM	LW53VK8XCM
35	20	25	15	3/32	3/32	.150	.156	LW53KK8XGM	LW53KK8XCM

WHEN ORDERING VALVES OR REPAIR PACKS ADD VOLTAGE AND FREQUENCY TO COMPLETE VALVE NUMBER. EXAMPLES: VALVE (LW53JJ8XGML-120/60) REPAIR PACK (KLW53JJD-AC)