

LOW WATT VALVES



Series 50 SSLW >> Model SSLW53

Encapsulated Low Wattage – 3-Way Normally Closed Valve (piped exhaust)

General purpose for pneumatic applications. For use on air and common gases, compatible with standard Buna seals. Other media require special seal materials. The SLLW Valve is not a safety valve.

- General purpose valve with reduced power consumption.
- For pneumatic and hydraulic application.
- NEMA 4 rating is standard with encapsulated coil.

OPERATING CONDITIONS

Media: Air and other common gases only.*

Valve Temperature Range: Standard Valves - 0°F (-18°C) to 140°F (60°C) ambient; 0°F (-18°C) to 150°F (65°C) media. Optional Valves - can tolerate much higher or much lower ambient and media temperatures.*

Maximum Operating Pressure Differentials: See table on proceeding page.

Burst Pressure: 5000 PSI

Leakage: Bubble tight for standard valves.

Vacuum: To 5 Microns*

ELECTRICAL CHARACTERISTICS

Coil Voltage: 1.9 to 63V DC

Nominal Power: DC – .50 Watts

Coil Construction: Encapsulated Class F Coil with third wire ground

Typical Response Time on Air: 4 - 16 Milliseconds

Operating Speed: Up to 600 CPM

Duty Cycle: Continuous

MECHANICAL CHARACTERISTICS

Body: Stainless Steel (Std.)

Internal Components: Stainless Steel

Elastomers: Nitrile (Buna) (Std.). Many other elastomers available.*

Orifice Diameter: See table on proceeding page.

Porting: 1/8" NPT (Std.)

Housing: Encapsulated with 1/2 NPT conduit

Listings: Most valves are UL and CSA listed – consult factory.

Life Expectancy: Millions of cycles, depending on application, lubrication, etc.

Valve Weight: 0.60 lbs

Repair Packs: See table on proceeding page.

Options: Alternate Port Locations, Metering, Alternate Elastomers, All Stainless Steel Construction*

* Consult representative or factory for options and specifications.

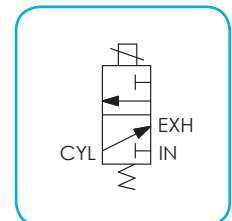
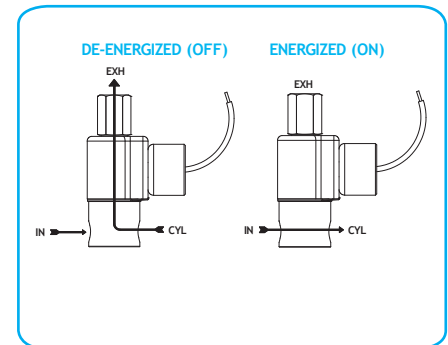

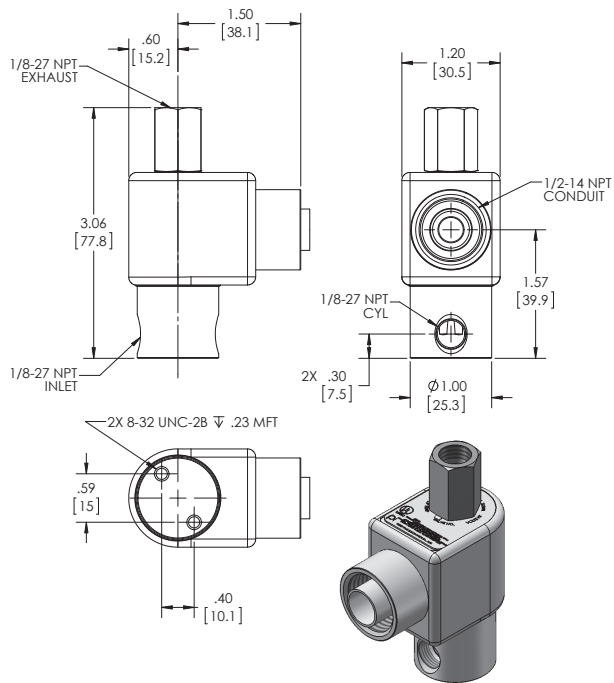

**SERIES 50 SLLW
MODEL SLLW53
3WNC PIPED EXHAUST
LOW WATT**

VALVE SPECIFICATIONS

MAX. OPER. PRESS. DIFF. DC GAS ONLY	ORIFICE SIZE		CV FACTOR		VALVE NUMBER
	N.C.	N.O.	N.C.	N.O.	
120	1/32	1/32	.022	.020	SLLW53GG8DCCP

WHEN ORDERING VALVES OR REPAIR PACKS ADD VOLTAGE AND FREQUENCY TO COMPLETE VALVE NUMBER. EXAMPLES: VALVE (SLLW53GGDCCP-12/DC) REPAIR PACK (KSLLW53GGD-DC)