

HAZARDOUS LOCATION VALVES



Series E50 >> Model E54

Hazardous Location – 3-Way Normally Open Valve

Our original mini – engineered for space economy without sacrificing performance. Typical applications include medical, analytical instrumentation. Air, water, and other fluids compatible with standard Buna seals. Hot water, steam, gasoline, and many oils require special seal materials.

- **Tough with options to use in hazardous location environments or low watt applications.**
- **High quality engineering.**

OPERATING CONDITIONS

Media: Air, and other fluids compatible with standard Buna seals. Hot water, steam, gasoline, oils, some hydraulic fluids, and many media require special seal materials. (Series 50 pressure ratings may change due to the viscosity of the liquid.)*

Valve Temperature Range: Standard Valves - 0°F (-18°C) to 104°F (40°C) ambient; 0°F (-18°C) to 150°F (65°C) media. Optional Valves - can tolerate much higher or much lower ambient and media temperatures.*

Maximum Operating Pressure Differentials: See table on proceeding page.

Burst Pressure: 5000 PSI

Leakage: Bubble tight for standard valves.

Vacuum: To 5 Microns*

ELECTRICAL CHARACTERISTICS

Coil Voltage: 6.0 to 575V AC 60 HZ. and 5.4 to 515V AC 50 HZ. – 3.0 to 300V DC.

Nominal Power: AC – 5.6 Watts DC – 7.2 Watts

Coil Construction: Molded Class F with third wire ground (Std.), Class H or Potted (Opt.)

Typical Response Time on Air: 4 - 16 Milliseconds

Operating Speed: Up to 600 CPM

Duty Cycle: Continuous

MECHANICAL CHARACTERISTICS

Body: Stainless Steel (Std.)

Internal Components: Stainless Steel

Elastomers: Nitrile (Buna) (Std.). Many other elastomers available.*

Orifice Diameter: See table on proceeding page.

Porting: 1/8" NPT (Std.)

Housing: Flame-Proof construction with 1/2" NPT conduit

Listings: Valves are UL listed and CSA certified for Hazardous Locations – Class I, Div 1, Group C and D - Class II, Div 1, Groups E, F, and G; Div 2, Groups C, D, E, F, and G

Life Expectancy: Millions of cycles, depending on application, lubrication, etc.

Valve Weight: 0.40 lbs

Repair Kits: See table on proceeding page.

Options: Alternate Port Locations, Metering, Alternate Elastomers, All Stainless Steel Construction*

* Consult representative or factory for options and specifications.

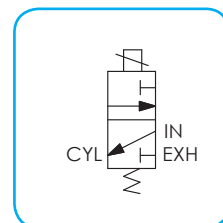
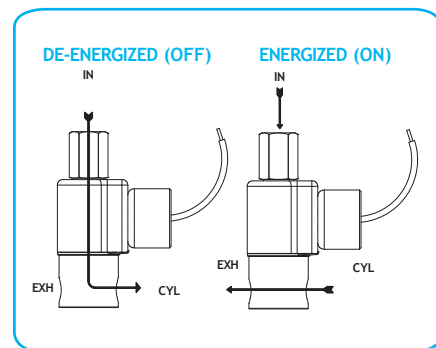

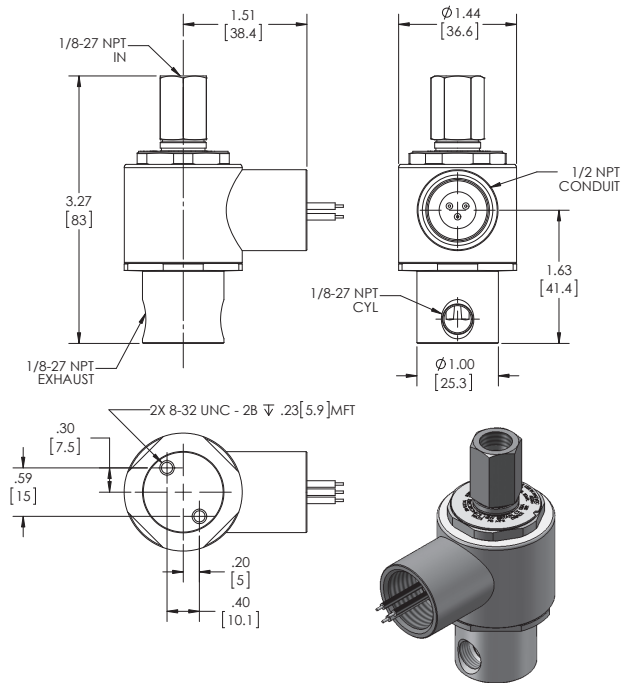

**SERIES 50
MODEL E54
3WNO
EXPLOSION PROOF**

VALVE SPECIFICATIONS

MAX. OPER. PRESS. DIFF.		ORIFICE SIZE		CV FACTOR		VALVE NUMBER
AC	DC	N.O.	N.C.	N.O.	N.C.	
150	150	1/32	1/32	.020	.022	E54GG8XCCM
125	125	3/64	3/64	.048	.055	E54HH8XCCM
100	75	1/16	1/16	.075	.075	E54JJ8XCCM
75	45	1/16	3/32	.075	.156	E54JK8XCCM
50	50	3/32	3/32	.156	.156	E54KK8XCCM
50	30	1/16	1/8	.075	.230	E54NJ8XCCM
40	25	3/32	1/8	.156	.230	E54NK8XCCM

WHEN ORDERING VALVES OR REPAIR KITS ADD VOLTAGE AND FREQUENCY TO COMPLETE VALVE NUMBER. EXAMPLES: VALVE (E54JK8XCCM-120/60) REPAIR KIT (5KE54JK-AC)