

HAZARDOUS LOCATION VALVES



Series 20 >> Model E22 C/I Rated

Hazardous Location – 2-Way Normally Closed Valve

Peter Paul offers a line of Hazardous Location rated, Automatic Safety Shut Off Valves designed specifically for gas appliances. These valves meet the standards for Commercial/Industrial (C/I) Safety Shut Off Valves per ANSI Z21.21 (CSA 6.5). They are well suited for use in heating equipment, furnaces, ovens, kilns, boilers and gas generators.

- Potted coil for outdoor service.
- Direct lift.
- Voltages: 120/60, 12/DC and 24/DC
- Rated for ambient temperatures of -40°C to $+65^{\circ}\text{C}$

OPERATING CONDITIONS

Media: Air, water, and other fluids compatible with standard Buna seals. Hot water, steam gasoline, and many oils require special seal materials. (Series 20 pressure ratings may change due to the viscosity of the liquid.)*

Valve Temperature Range: Standard Valves - 0°F (-18°C) to 104°F (40°C) ambient; 0°F (-18°C) to 150°F (65°C) media. Optional Valves - can tolerate much higher or much lower ambient and media temperatures.*

Maximum Operating Pressure Differentials: See table on proceeding page.

Burst Pressure: 5000 PSI

Leakage: Bubble tight for standard valves.

Vacuum: To 5 Microns*

ELECTRICAL CHARACTERISTICS

Coil Voltage: 6 to 825V AC 60 HZ. and 5 to 720V AC 50 HZ. – 1.8 to 265V DC

Nominal Power: AC – 7.3 Watts DC – 9.5 Watts

Coil Construction: Molded Class F with third wire ground (Std.), Class H or Potted (Opt.)

Typical Response Time on Air: 4 - 16 Milliseconds

Operating Speed: Up to 600 CPM

Duty Cycle: Continuous

MECHANICAL CHARACTERISTICS

Body: Stainless Steel (Std.) or Brass (Opt.)

Internal Components: Stainless Steel

Elastomers: Nitrile (Buna) (Std.). Many other elastomers available.*

Orifice Diameter: See table on proceeding page.

Porting: 1/4" NPT

Housing: Flame-Proof construction with 1/2" NPT conduit

Listings: Valves are UL listed and certified for Hazard Locations – Class I, Div 1, Group C and D - Class II, Div 1, Group E, F, and G; Div 2, Groups C, D, E, F, and G.

Life Expectancy: Millions of cycles, depending on application, lubrication, etc.

Valve Weight: 1.38 lbs

Repair Kits: See table on proceeding page.

Options: Alternate Port Locations, Metering, Manual Override, Alternate Elastomers*

* Consult representative or factory for options and specifications.

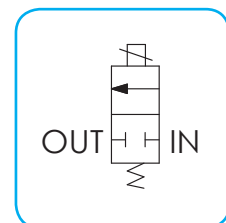
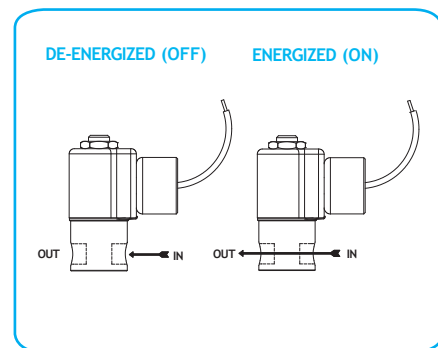

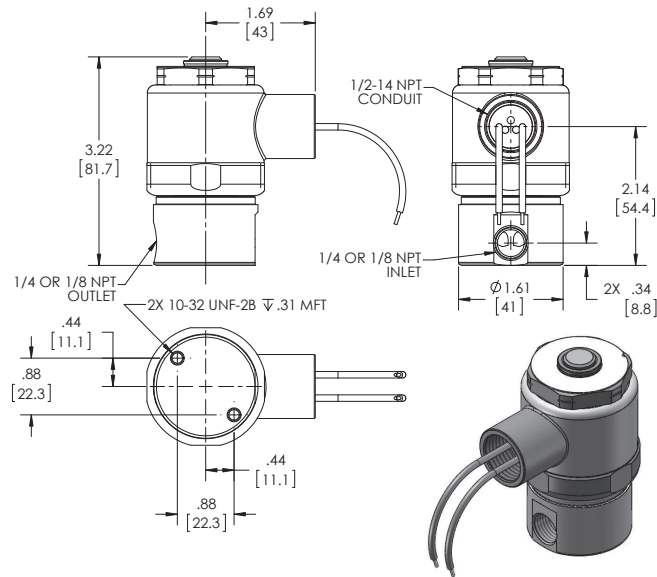

**SERIES 20 MODEL E22
2WNC
EXPLOSION PROOF**

VALVE SPECIFICATIONS

MAX. OPER. PRESS. DIFF.		GAS CAPACITY		PIPE SIZE	VALVE NUMBER
AC	DC	BTU/Hr	CV FACTOR		
		N.C.	N.C.		
	50	400,000	.404	1/4 NPT	E22Z0196YCCP 24/DC
50		400,000	.404	1/4 NPT	E22Z0197YCCP 120/60
	50	400,000	.404	1/4 NPT	E22Z0198YCCP 12/DC

REPAIR KITS (2KE22Z0196-DC for DC voltages; 2KE22Z0197-AC for AC voltages)