

GENERAL PURPOSE VALVES

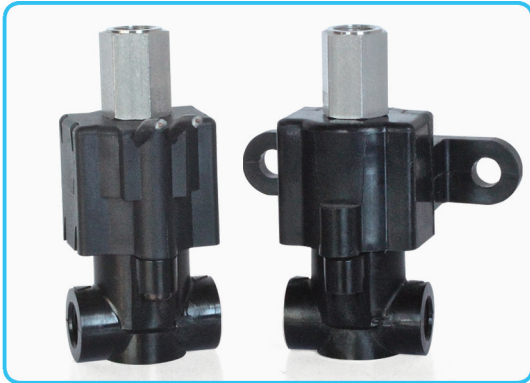

Series 40 >> Model 43

All-Plastic — 3-Way Normally Closed Valve — Piped Exhaust

General purpose valve engineered for economical applications. Engineered for competitive cost and reliable service. The valves can be used with air, inert gas and liquid media.

- **Cost competitive.**
- **Molded plastic exterior with internal stainless steel parts.**
- **Engineered with proven performance and reliable service.**
- **Also available with a forged brass body and integral mounting bracket.**
- **Great for humidifiers, pneumatic actuation systems, beverage dispensers and other equipment.**

OPERATING CONDITIONS

Media: Air, inert gases and liquid media. (Series 40 pressure ratings may change due to the viscosity of the liquid.)*

Valve Temperature Range: Standard Valves - 0°F (-18°C) to 104°F (40°C) ambient; 0°F (-18°C) to 150°F (65°C) media. Optional Valves - can tolerate much higher or much lower ambient and media temperatures. Do NOT allow water to freeze when using plastic body.

Maximum Operating Pressure Differentials: See table on proceeding page.

Burst Pressure: 1000 PSI

Leakage: Bubble tight for standard valves.

Vacuum: To 5 Microns*

ELECTRICAL CHARACTERISTICS

Coil Voltage: 12 to 252V AC 60 HZ. and 10.5 to 221V AC 50 HZ. — 4.7 to 100V DC

Nominal Power: AC — 3.3 Watts DC — 5.0 Watts

Coil Construction: Encapsulated Molded Class B with 24" leads

Typical Response Time on Air: 4 - 16 Milliseconds

Operating Speed: Up to 600 CPM

Duty Cycle: Continuous

MECHANICAL CHARACTERISTICS

Body: Polyester Plastic (Std.) or Forged Brass (Opt.)

Internal Components: Stainless Steel

Elastomers: Nitrile (Buna) (Std.). Many other elastomers available.*

Orifice Diameter: See table on proceeding page.

Porting: 1/8" NPT

Housing: Grommet

Listings: Most valves are UL and CSA listed.*

Life Expectancy: Millions of cycles, depending on application, lubrication, etc.

Valve Weight: 0.27 lbs average (with plastic body)

Repair Packs: See table on proceeding page.

Options: Forged brass body in various porting styles.*

* Consult representative or factory for options and specifications.

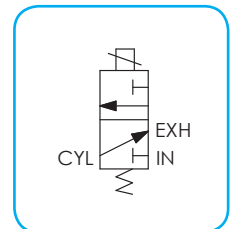
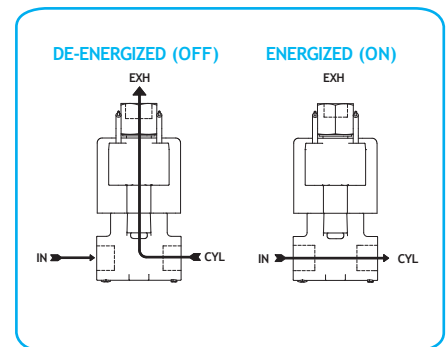

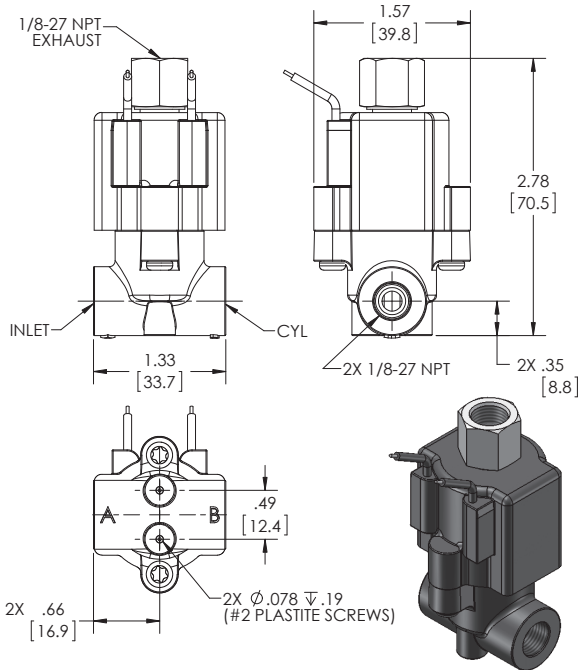

**SERIES 40
MODEL 43 (NO BRACKET)
3WNC PIPED EXHAUST
MOLDED WITH LEADS**

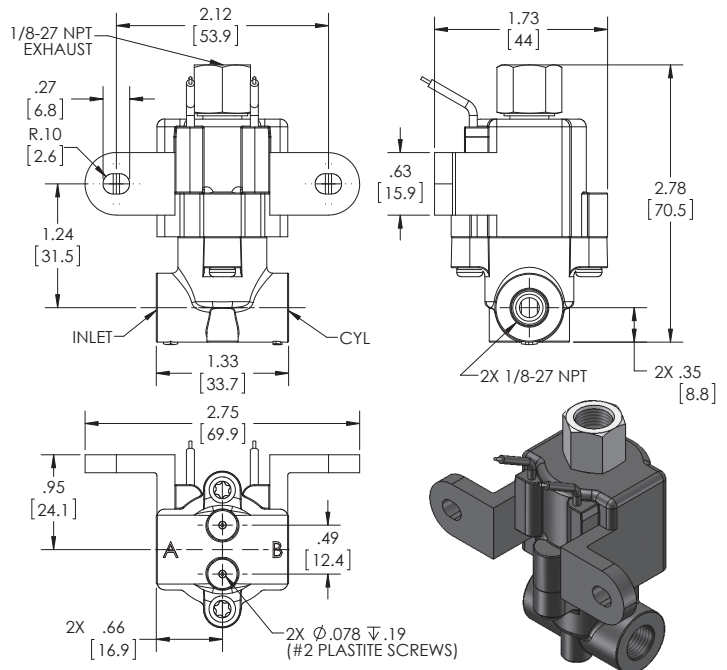

**SERIES 40
MODEL 43 (WITH BRACKET)
3WNC PIPED EXHAUST
MOLDED WITH LEADS**

VALVE SPECIFICATIONS

MAX. OPER. PRESS. DIFF.		ORIFICE SIZE		CV FACTOR		VALVE NUMBER	
AC	DC	N.C.	N.O.	N.C.	N.O.	WITHOUT BRACKET	WITH BRACKET
150	150	1/16	1/16	.090	.075	43JJ15XGM	43JJ15XBGM
60	60	3/32	3/32	.145	.145	43KK15XGM	43KK15XBGM
30	30	1/8	3/32	.200	.145	43NK15XGM	43NK15XBGM

WHEN ORDERING VALVES OR REPAIR PACKS ADD VOLTAGE AND FREQUENCY TO COMPLETE VALVE NUMBER. EXAMPLES: VALVE (43JJ15XGM-120/60) REPAIR PACK (K43JJX-AC).