

HAZARDOUS LOCATION VALVES



Series 50 ELW >> Model ELW53

Encapsulated Low Wattage Hazardous Location – 3-Way Normally Closed Valve (exhaust to atmosphere)

A UL and CSA listed, low watt, miniature hazardous location valve with minimal space and energy requirements in volatile environments. Air and other fluids, compatible with standard Buna seals. Hot water, steam, gasoline, oils, some hydraulic fluids, and many other media require special seal materials.

- **Smallest hazardous location solenoid valve.**
- **Best ambient and high temperature ratings on the market.**
- **NEMA 4 rating is standard with encapsulated coil.**

OPERATING CONDITIONS

Media: Air, and other fluids compatible with standard Buna seals. Hot water, steam, gasoline, oils, some hydraulic fluids, and many media require special seal materials. (Series 50 pressure ratings may change due to the viscosity of the liquid.)*

Valve Temperature Range: Standard Valves - 0°F (-18°C) to 140°F (60°C) ambient; 0°F (-18°C) to 150°F (65°C) media. Optional Valves - can tolerate much higher or much lower ambient and media temperatures.*

Maximum Operating Pressure Differentials: See table on proceeding page.

Burst Pressure: 5000 PSI

Leakage: Bubble tight for standard valves.

Vacuum: To 5 Microns*

ELECTRICAL CHARACTERISTICS

Coil Voltage: 12 to 370V AC 60 HZ. and 10.5 to 345V AC 50 HZ. – 3.5 to 120V DC

Nominal Power: AC – 1.8 Watts DC – 1.8 Watts

Coil Construction: Encapsulated Class F Coil with third wire ground

Typical Response Time on Air: 4 - 16 Milliseconds

Operating Speed: Up to 600 CPM

Duty Cycle: Continuous

MECHANICAL CHARACTERISTICS

Body: Stainless Steel (Std.)

Internal Components: Stainless Steel

Elastomers: Nitrile (Buna) (Std.). Many other elastomers available.*

Orifice Diameter: See table on proceeding page.

Porting: 1/8" NPT (Std.)

Housing: Encapsulated with 1/2 NPT conduit

Listings: Valves are UL listed for Hazardous Locations – Class I, Div 1, Groups A, B, C, and D - Class II, Div 1, Groups E, F, and G; Div 2, Groups A, B, C, D, E, F, and G. "T" Rating as low as T5.

Life Expectancy: Millions of cycles, depending on application, lubrication, etc.

Valve Weight: 0.60 lbs

Repair Packs: See table on proceeding page.

Options: Alternate Port Locations, Metering, Alternate Elastomers, All Stainless Steel Construction*

* Consult representative or factory for options and specifications.

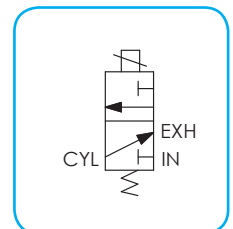
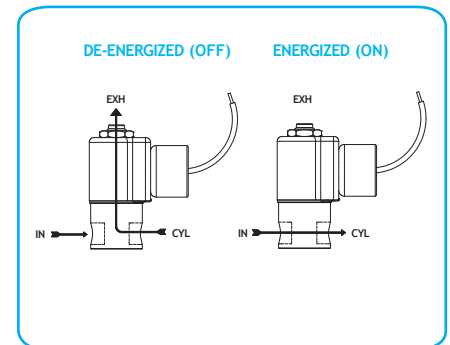

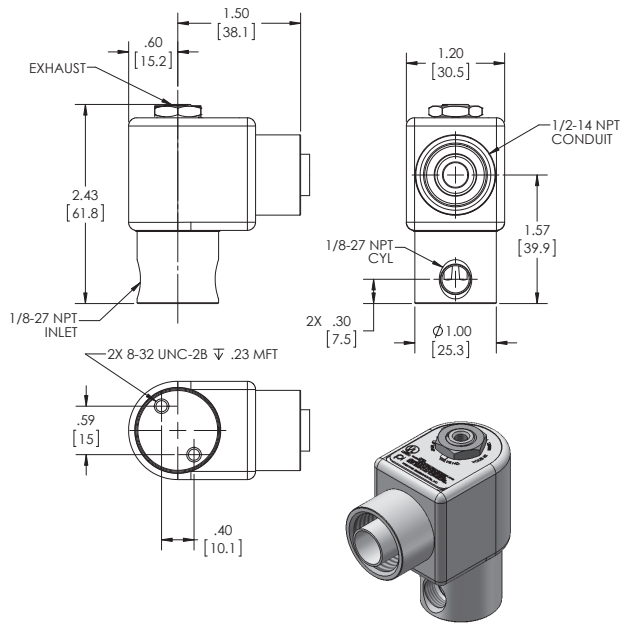

**SERIES 50 ELW
MODEL ELW53
3WNC EXHAUST TO ATMOSPHERE
EXPLOSION PROOF**

VALVE SPECIFICATIONS

MAX. OPER. PRESS. DIFF. GAS		MAX. OPER. PRESS. DIFF. LIQUID		ORIFICE SIZE		CV FACTOR		VALVE NUMBER
AC	DC	AC	DC	N.C.	N.O.	N.C.	N.O.	
215	135	215	135	1/32	1/32	.022	.020	ELW53GG8DCCP
215	120	120	65	1/32	3/64	.022	.048	ELW53GH8DCCP
135	50	40	30	1/32	1/16	.022	.075	ELW53GJ8DCCP
70	35	30	20	1/32	5/64	.022	.134	ELW53GV8DCCP
55	30	25	15	1/32	3/32	.022	.150	ELW53GK8DCCP
120	70	120	65	3/64	3/64	.055	.048	ELW53HH8DCCP
120	50	40	30	3/64	1/16	.055	.075	ELW53HJ8DCCP
70	35	30	20	3/64	5/64	.055	.134	ELW53HV8DCCP
55	30	25	15	3/64	3/32	.055	.150	ELW53HK8DCCP
85	40	40	30	1/16	1/16	.075	.075	ELW53JJ8DCCP
70	35	30	20	1/16	5/64	.075	.134	ELW53JV8DCCP
55	30	25	15	1/16	3/32	.075	.150	ELW53JK8DCCP
50	30	30	20	5/64	5/64	.134	.134	ELW53VV8DCCP
50	30	25	15	5/64	3/32	.134	.150	ELW53VK8DCCP
35	20	25	15	3/32	3/32	.156	.150	ELW53KK8DCCP

WHEN ORDERING VALVES OR REPAIR PACKS ADD VOLTAGE AND FREQUENCY TO COMPLETE VALVE NUMBER. EXAMPLES: VALVE (ELW53JJ8DCCPL-120/60) REPAIR PACK (KELW53JJDL-AC)