



**PETER
PAUL**

electronics co., inc.

Large Orifice Solenoid Valves

for Chemical, Petrochemical,
Pharmaceutical, Food, Beverage
and Other Wet Process Industries



Excellence by Control

Series 80 *High Flow Valves for Your Processes*

Peter Paul offers a line of large orifice solenoid valves to address process industry requirements for high flow rate or quick dump and fill capacity. These AC or DC powered valves are also suited for low pressure gas and liquid applications. Port sizes range from 3/8" to 3" NPT, with pressure ratings from 0 to 200 PSI. Direct-Lift or Internal Pilot models are available in Normally Closed, Normally Open and Explosion Proof versions.

Figure A

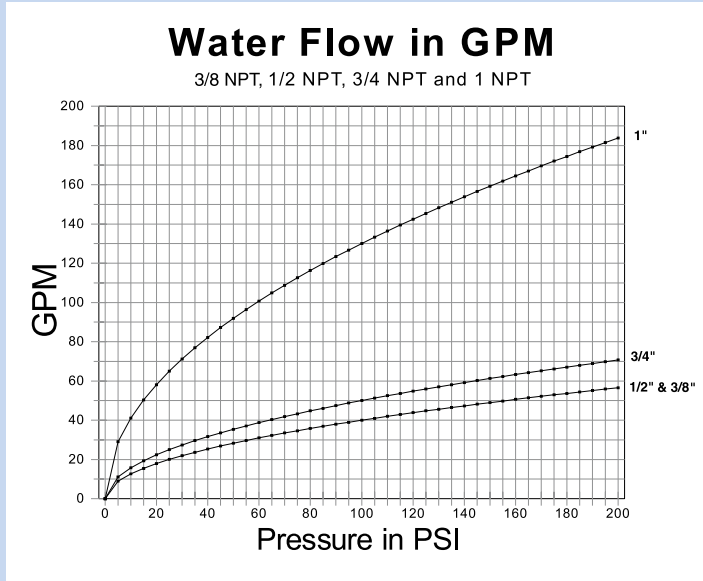
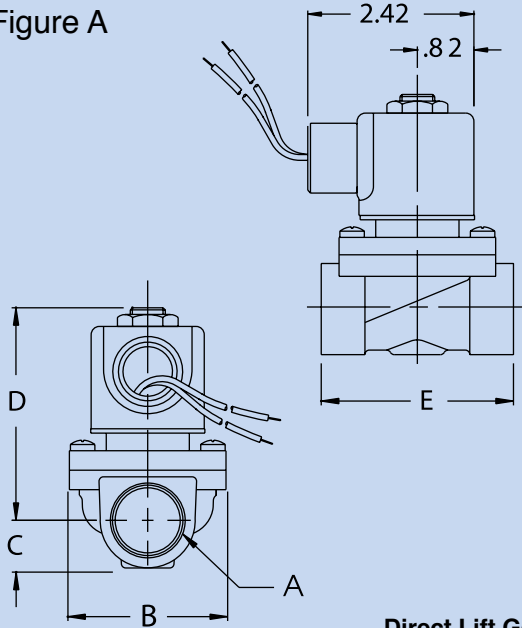

Direct Lift General Dimensions

A	B	C	D	E
3/8"	2.01 (51.1)	.61 (15.5)	3.02 (76.7)	2.36 (59.9)
1/2"	2.01 (51.1)	.61 (15.5)	3.02 (76.7)	2.36 (59.9)
3/4"	2.28 (57.9)	.69 (17.5)	3.10 (78.7)	2.83 (71.9)

Metric sizes in parenthesis

Valve Type	Valve Number	Figure	Orifice Size	Pipe Size	Max. Oper. Pressure AC	DC	Min. Oper. Pressure	CV Factor
NC - Direct Lift	827T20DCV	A	0.50	3/8 NPT	100	40	0 PSI	4
NC - Direct Lift - Explosion Proof	E827T20DCCM	A	0.50	3/8 NPT	100	40	0 PSI	4
NC - Direct Lift	827B12DCV	A	0.50	1/2 NPT	100	40	0 PSI	4
NO - Internal Pilot	818B12DCV	A	0.50	1/2 NPT	150	150	3 PSI	4
NC - Internal Pilot	828B12DCV	A	0.50	1/2 NPT	200	200	3 PSI	4
NC - Direct Lift - Explosion Proof	E827B12DCCM	A	0.50	1/2 NPT	100	40	0 PSI	4
NC - Internal Pilot - Explosion Proof	E828B12DCCM	A	0.50	1/2 NPT	200	200	3 PSI	4
NC - Direct Lift	827Y19DCV	A	0.75	3/4 NPT	100	30 (75)	0 PSI	5
NO - Internal Pilot	818Y19DCV	A	0.75	3/4 NPT	200	200	3 PSI	5.8
NC - Direct Lift - Explosion Proof	E827Y19DCCM	A	0.75	3/4 NPT	100	30	0 PSI	5
NC - Internal Pilot	828Y19DCV	B	0.75	3/4 NPT	200	200	3 PSI	5.8
NC - Internal Pilot - Explosion Proof	E828Y19DCCM	B	0.75	3/4 NPT	200	200	3 PSI	5.8
NO - Internal Pilot	818D13DCV	B	1	1 NPT	200	200	3 PSI	13
NC - Internal Pilot	828D13DCV	B	1	1 NPT	200	200	3 PSI	13

Model 827 is a solenoid operated diaphragm valve that can operate at low pressures without any differential pressure across the diaphragm (Direct Lift).

Main Characteristics

- Forged brass or 316 stainless steel body
- NPT threaded connections
- Normally Closed and Normally Open
- Buna, EPDM, FKM, Teflon, Neoprene Seals

Options (see page 4)

- Explosion-Proof
- Multiple housing options
- Multiple coil options
- Solid state timer

Figure B

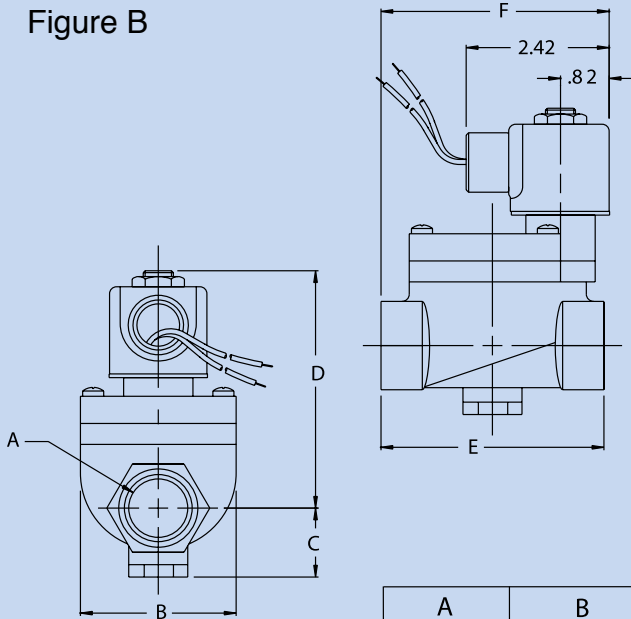

Water Flow in GPM

1.5 NPT, 2 NPT, 2.5 NPT and 3 NPT

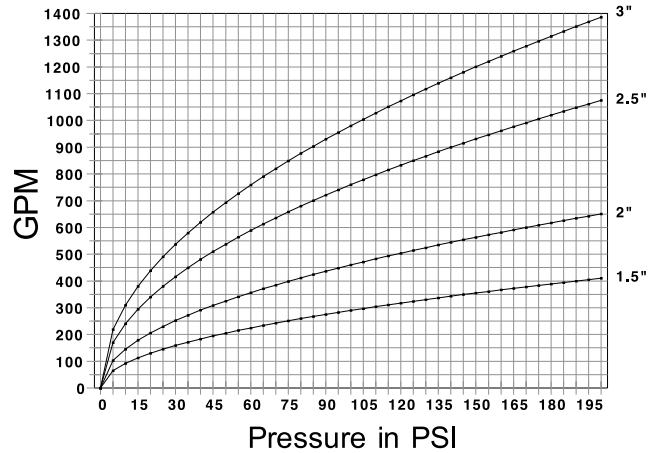

A	B	C	D	E	F
1/2"	1.75 (44.4)	.67 (17.2)	3.97 (100.1)	2.56 (65.0)	2.80 (71.1)
3/4"	2.05 (52.1)	1.02 (25.9)	3.91 (99.3)	2.80 (71.1)	2.88 (73.2)
1"	2.64 (67.1)	1.18 (30.0)	4.06 (103.1)	3.78 (96.0)	3.87 (98.3)
1-1/2"	3.19 (81.0)	1.42 (36.1)	4.50 (114.3)	4.49 (114.0)	4.58 (116.3)
2"	3.82 (97.0)	1.73 (43.9)	4.73 (120.1)	5.04 (128.0)	5.13 (130.3)
2-1/2-3"	6.42 (163.1)	3.50 (88.9)	8.24 (209.3)	8.82 (224.0)	8.91 (226.3)

Valve Type	Valve Number	Figure	Orifice Size	Pipe Size	Max. Oper. Pressure AC	DC	Min. Oper. Pressure	CV Factor
NO - Internal Pilot	818E14DCV	B	1.5	1-1/2 NPT	200	200	3 PSI	29
NC - Internal Pilot	828E14DCV	B	1.5	1-1/2 NPT	200	200	3 PSI	29
NO - Internal Pilot	818F16DCV	B	2	2 NPT	200	200	3 PSI	46
NC - Internal Pilot	828F16DCV	B	3	2-1/2 NPT	200	200	3 PSI	76
NC - Internal Pilot	828W17DCV	B	3	2-1/2 NPT	200	200	3 PSI	76
NO - Internal Pilot	818W18DCV	B	3	3 NPT	200	200	3 PSI	98
NC - Internal Pilot	828W18DCV	B	3	3 NPT	200	200	3 PSI	98
NC - Internal Pilot - Explosion Proof	E828D13DCCM	B	1	1 NPT	200	200	3 PSI	13
NC - Internal Pilot - Explosion Proof	E828E14DCCM	B	1.5	1-1/2 NPT	200	200	3 PSI	29
NC - Internal Pilot - Explosion Proof	E828F16DCCM	B	2	2 NPT	200	200	3 PSI	46
NC - Internal Pilot - Explosion Proof	E828W17DCCM	B	3	2-1/2 NPT	200	200	3 PSI	76
NC - Internal Pilot - Explosion Proof	E828W18DCCM	B	3	3 NPT	200	200	3 PSI	98

Models 818 and 828 are solenoid operated diaphragm and piston valves that use a differential pressure principal (Internal Pilot).

Series 80 Specifications

Operating Conditions

Media	Air, water, and other fluids compatible with standard Buna seals. Hot water, steam gasoline, and many oils require special seal materials. Consult representative or factory.
Valve Temp. Range	Standard Valves: 0°F (-18°C) to 104°F (40°C) ambient; 0°F (-18°C) to 150°F (65°C) media. Optional Valves: can tolerate much higher or much lower ambient and media temperatures. Consult factory for specifics.
Burst Pressure	5000 PSI
Leakage	Bubble tight for standard valves

Electrical Characteristics

Coil Voltage	5 to 825 VAC 50-60 Hz. - 1.8 to 265V DC
Nominal Power	9.5 DC, 7.7 watts AC
Coil Construction	Class A, Class F, Class H
Typical Response Time on Air	8-50 Milliseconds

Mechanical Characteristics

Housing	Grommet & 1/2" NPT conduit - many options available
Hazardous Locations	Class I; Group C and D - Class II; Group E, F, & G

Options

Housing

- Strain Relief Connector
- Double Automotive
- Splice Box Housing
- Single Automotive
- "AN" Connector
- Yoke

Coil

- Molded Coil
- Potted Coil & Housing
- High Temperature Molded Coil
- Third Wire Ground
- Spade Terminal - Coil - Molded

Solid State Timer (see photo below)

Specifications

Voltage	120 AC to 240 AC
Nominal Power Consumption	9.5 watts
Line Cord	6 ft. w/ three prong plug
Timer Adjustment	Off Time 1 to 45 min. On Time .25 sec. to 25 sec.
Push Button Manual Override	
Status Lights	to show power and operation. Timer and coil may be rotated 360°

AIR FLOW RATE IN CFM AT 70 DEG. F

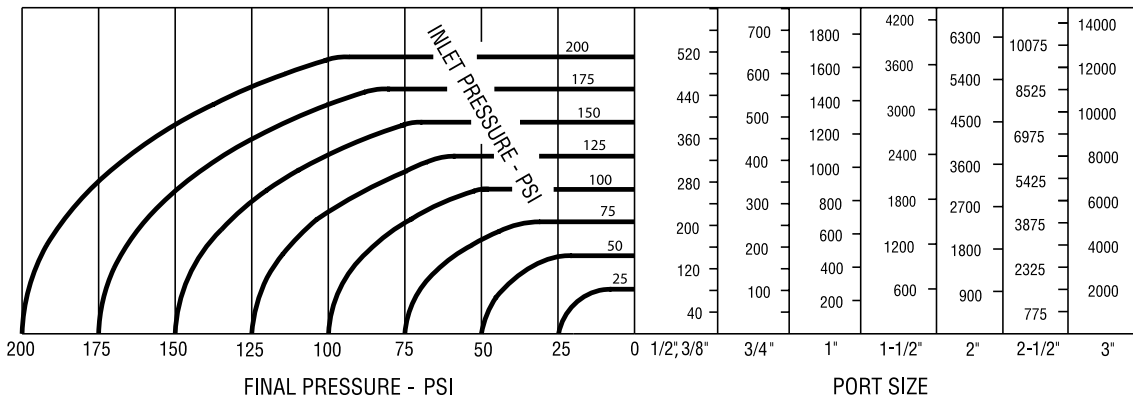

Solid State Timer

Valve Order Numbering System

1st Digit	2nd Digit	3rd Digit	4th Digit	5th Digit	6th Digit	7th Digit	8th Digit	9th Digit
Series Designation	Type	Orifice	Port Size & Body Mat. BR SS	Body Port & Function Options	Housing Options	Coil Options	Voltage	Frequency
8 Series 80	18 Internal Pilot 2WNO	T 3/8"	3/8" NPT 20	D No Option	C Conduit	V Non-Molded	Full Description Required 120v, 240v	Full AC Description Required 50 Hz, 60Hz or DC
	27 Direct Lift 2WNC	B 1/2"	1/2" NPT 12	Y Manual Override	G Grommet	M Molded		
	28 Internal Pilot 2WNC	C 3/8"	3/4" NPT 19 29		CC Conduit with 3rd wire ground	H High Temp. 180°C		
		Y 3/4"	1" NPT 13 23		EM European Din Coil	P Potted Coil & Housing		
		D 1"	1-1/2" NPT 14 24					
		E 1-1/2"	2" NPT 16 26					
		F 2"	2-1/2" NPT 17 27					
		W 3"	3" NPT 18 28					

EXAMPLE

8	28	D	13	D	C	M	120	60
Series 80 Valve	Internal Pilot	1" Orifice	1" NPT Brass	No option	Conduit Housing	Molded Coil	120 Volt	AC 60 Hz

NOTE: "E" Marked prior to the valve number denotes Explosion Proof.

WARRANTY

Peter Paul Electronics Co., Inc. (seller) warrants its products to be free from defects in workmanship and material. Under normal use and service, Peter Paul products will perform very satisfactorily. The seller's obligation under this warranty shall be limited to the repairing, free of charge, any part or valve which, after his examination, shows it to be defective. Of course, normal wear and tear must be considered and exempted. No representative or person is authorized to assume for the seller any other obligation or liability in connection with the sale of its sale of its products.

All engineering and technical advice are offered free of charge, in a spirit of helpfulness to the buyer. This assistance is based on data which Peter Paul considers reliable and is intended to be used by knowledgeable and skillful personnel at their own risk.

The seller shall not be liable for consequential damages in case of failure to meet conditions of any guarantee or shipping schedule, nor claims for labor, loss of profits, repairs or other expenses incidental to replacement.



PETER PAUL

electronics co., inc.

P.O. Box 1180, 480 John Downey Drive

New Britain, CT 06050-1180

Tel 860-229-4884 Fax 860-223-1734

www.peterpaul.com

info@peterpaul.com