

GENERAL PURPOSE VALVES



Series 50 >> Model 51

2-Way Normally Open Valve

Our original mini – engineered for space economy without sacrificing performance. Typical applications include medical, analytical instrumentation. Air, water, and other fluids compatible with standard Buna seals. Hot water, steam, gasoline, and many oils require special seal materials.

- Tough with options to use in hazardous location environments or low watt applications.
- High quality engineering.

Note: This valve also available as an operator. Refer to following page.

OPERATING CONDITIONS

Media: Air, water, and other fluids compatible with standard Buna seals. Hot water, steam, gasoline, and many oils require special seal materials. (Series 50 pressure ratings may change due to the viscosity of the liquid.)*

Valve Temperature Range: Standard Valves - 0°F (-18°C) to 104°F (40°C) ambient; 0°F (-18°C) to 150°F (65°C) media. Optional Valves - can tolerate much higher or much lower ambient and media temperatures.*

Maximum Operating Pressure Differentials: See table on proceeding page.

Burst Pressure: 5000 PSI

Leakage: Bubble tight for standard valves.

Vacuum: To 5 Microns*

ELECTRICAL CHARACTERISTICS

Coil Voltage: 6.0 to 575V AC 60 HZ. and 5.4 to 515V AC 50 HZ. – 3.0 to 300V DC

Nominal Power: AC – 6.0 Watts, DC – 7.0 Watts

Coil Construction: Molded and potted Class F. (Class H optional)

Typical Response Time on Air: 4 - 16 Milliseconds

Operating Speed: Up to 600 CPM

Duty Cycle: Continuous

MECHANICAL CHARACTERISTICS

Body: Stainless Steel (Std.), Brass (Opt.) or Aluminum (Opt.)

Internal Components: Stainless Steel

Elastomers: Nitrile (Buna) (Std.). Many other elastomers available.*

Orifice Diameter: See table on proceeding page.

Porting: Standard 1/8" NPT (other ports available).*

Housing: Grommet and 1/2" NPT conduit - many options available.*

Listings: Most valves are UL and CSA listed.*

Life Expectancy: Millions of cycles, depending on application, lubrication, etc.

Valve Weight: Grommet Valve: 0.38 lb Conduit Valve: 0.44 lb

Repair Packs: See table on proceeding page.

Options: Alternate Port Locations, Metering, Alternate Elastomers, Low Wattage, Spade Terminal Coil and Explosion Proof

* Consult representative or factory for options and specifications.

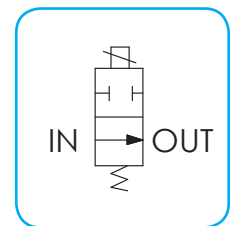
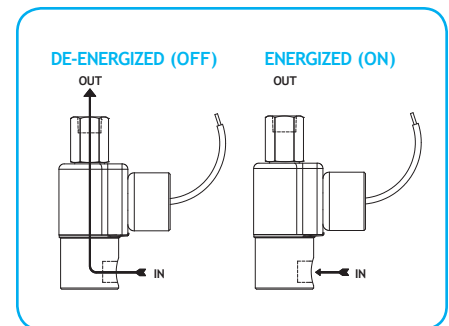

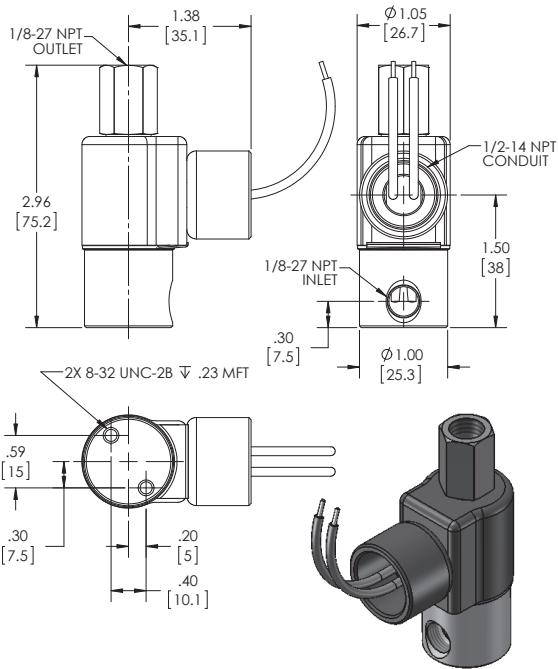

**SERIES 50
MODEL 51
2WNO
CONDUIT CONNECTION**

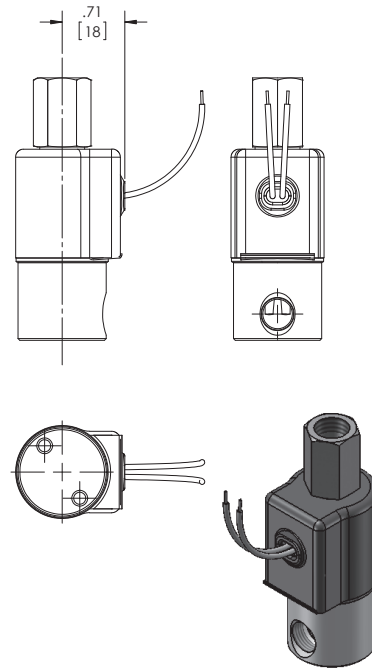

**SERIES 50
MODEL 51
2WNO
GROMMET HOUSING WITH LEADS**

VALVE SPECIFICATIONS

| MAX. OPER. PRESS. DIFF. | | ORIFICE SIZE N.O. | CV FACTOR N.O. | VALVE NUMBER | |
|-------------------------|-----|----------------------|-------------------|----------------------------------|----------------------------------|
| AC | DC | | | GROMMET HOUSING 1/8 NPT PORTS | CONDUIT HOUSING 1/8 NPT PORTS |
| 400 | 200 | 1/32 | .020 | 51G8XGM | 51G8XCM |
| 200 | 100 | 3/64 | .048 | 51H8XGM | 51H8XCM |
| 125 | 60 | 1/16 | .075 | 51J8XGM | 51J8XCM |
| 40 | 40 | 3/32 | .150 | 51K8XGM | 51K8XCM |

ORDERING INFORMATION:

WHEN ORDERING VALVES OR REPAIR PACKS ADD VOLTAGE AND FREQUENCY TO COMPLETE VALVE NUMBER. EXAMPLES: VALVE (51J8XGM 120/60) REPAIR PACK (K51JDX AC)

WHEN ORDERING OPERATORS ADD THE LETTER "O" TO THE FRONT OF THE VALVE NUMBER, REPLACE BODY PORT NUMBER WITH THE LETTER "D": EXAMPLE: OPERATOR (O51J8DGM 120/60)