



Series E50 >> Model E52

Hazardous Location – 2-Way Normally Closed Valve

Peter Paul explosion proof valves are used where fire or explosion hazards exist due to the presence of flammable gases or vapors, flammable liquids, combustible dust, or easily ignitable fibers. Hazardous Location valves are recommended, or in some cases compulsory, where a high level of protection from explosion is required.

- **Miniature Hazardous Location valve.**
- **Flame-Proof construction.**
- **High quality engineering.**

Note: This valve also available as an operator. Refer to following page.

OPERATING CONDITIONS

Media: Air, and other fluids compatible with standard Buna seals. Hot water, steam, gasoline, oils, some hydraulic fluids, and many media require special seal materials. (Series 50 pressure ratings may change due to the viscosity of the liquid.)*

Valve Temperature Range: Standard Valves - 0°F (-18°C) to 104°F (40°C) ambient; 0°F (-18°C) to 150°F (65°C) media. Optional Valves - can tolerate much higher or much lower ambient and media temperatures.*

Maximum Operating Pressure Differentials: See table on proceeding page.

Burst Pressure: 5000 PSI

Leakage: Bubble tight for standard valves.

Vacuum: To 5 Microns*

ELECTRICAL CHARACTERISTICS

Coil Voltage: 6.0 to 575V AC 60 HZ. and 5.4 to 515V AC 50 HZ. – 3.0 to 300V DC.

Nominal Power: AC – 4.0 Watts DC – 7.2 Watts

Coil Construction: Molded Class F with third wire ground (Std.), Class H or Potted (Opt.)

Typical Response Time on Air: 4 - 16 Milliseconds

Operating Speed: Up to 600 CPM

Duty Cycle: Continuous

MECHANICAL CHARACTERISTICS

Body: Stainless Steel (Std.)

Internal Components: Stainless Steel

Elastomers: Nitrile (Buna) (Std.). Many other elastomers available.*

Orifice Diameter: See table on proceeding page.

Porting: 1/8" NPT (Std.)

Housing: Flame-Proof construction with 1/2" NPT conduit

Listings: Valves are UL listed and CSA certified for Hazardous Locations – Class I, Div 1, Group C and D - Class II, Div 1, Groups E, F, and G; Div 2, Groups C, D, E, F, and G

Life Expectancy: Millions of cycles, depending on application, lubrication, etc.

Valve Weight: 0.65 lbs

Repair Kits: See table on proceeding page.

Options: Alternate Port Locations, Metering, Alternate Elastomers, All Stainless Steel Construction*

* Consult representative or factory for options and specifications.

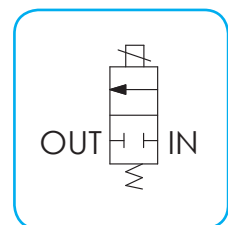
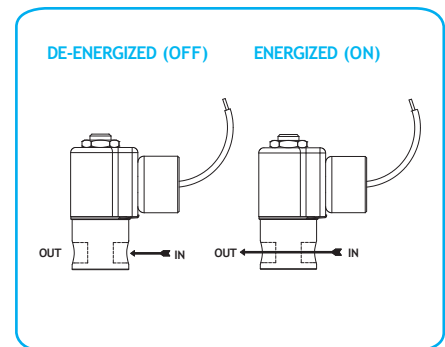

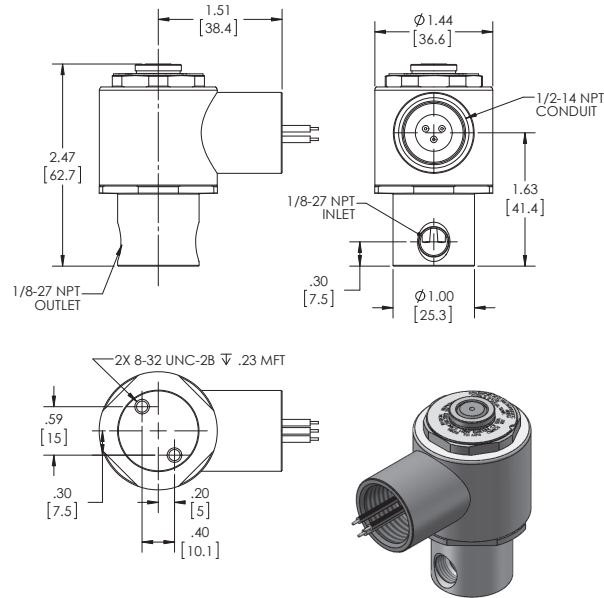

**SERIES E50
MODEL E52
2WNC
EXPLOSION PROOF**

VALVE SPECIFICATIONS

MAX. OPER. PRESS. DIFF.		ORIFICE SIZE	CV FACTOR	VALVE NUMBER
AC	DC	N.C.	N.C.	
500	250	1/32	.022	E52G8DCCM
400	150	3/64	.055	E52H8DCCM
200	100	1/16	.075	E52J8DCCM
100	45	3/32	.156	E52K8DCCM
75	25	1/8	.230	E52N8DCCM

ORDERING INFORMATION:

WHEN ORDERING VALVES OR REPAIR PACKS ADD VOLTAGE AND FREQUENCY TO COMPLETE VALVE NUMBER. EXAMPLES: VALVE (E52K8DCCM 120/60) REPAIR PACK (5KE52K AC)

WHEN ORDERING OPERATORS ADD THE LETTER "O" TO THE FRONT OF THE VALVE NUMBER, REPLACE BODY PORT NUMBER WITH THE LETTER "D": EXAMPLE: OPERATOR (OE52K8DCCM 120/60)