



Note: This valve also available as an operator. Refer to following page.

Series 50 SLW >> Model SLW52

Encapsulated Low Wattage – 2-Way Normally Closed Valve

General purpose or safety valves for pneumatic and hydraulic applications. The versatility of these valves is increased to include the handling of hot air, hot water, refrigerants and many other media, by the use of different seals. Air and other fluids compatible with standard Buna seals. Hot water, steam, gasoline, oils, some hydraulic fluids, and many media require special seal materials.

- General purpose valve with reduced power consumption.
- For pneumatic and hydraulic application.
- NEMA 4 rating is standard with encapsulated coil.

OPERATING CONDITIONS

Media: Air and other fluids compatible with standard Buna seals. Hot water, steam, gasoline, oils, some hydraulic fluids, and many media require special seal materials. (Series 50 pressure ratings may change due to the viscosity of the liquid.)*

Valve Temperature Range: Standard Valves - 0°F (-18°C) to 140°F (60°C) ambient; 0°F (-18°C) to 150°F (65°C) media. Optional Valves - can tolerate much higher or much lower ambient and media temperatures.*

Maximum Operating Pressure Differentials: See table on proceeding page.

Burst Pressure: 5000 PSI

Leakage: Bubble tight for standard valves.

Vacuum: To 5 Microns*

ELECTRICAL CHARACTERISTICS

Coil Voltage: 12 to 370V AC 60 HZ. and 10.5 to 345V AC 50 HZ. – 3.5 to 120V DC

Nominal Power: AC – 1.8 Watts DC – 1.8 Watts

Coil Construction: Encapsulated Class F Coil with third wire ground

Typical Response Time on Air: 4 - 16 Milliseconds

Operating Speed: Up to 600 CPM

Duty Cycle: Continuous

MECHANICAL CHARACTERISTICS

Body: Stainless Steel (Std.)

Internal Components: Stainless Steel

Elastomers: Nitrile (Buna) (Std.). Many other elastomers available.*

Orifice Diameter: See table on proceeding page.

Porting: 1/8" NPT (Std.)

Housing: Encapsulated with 1/2 NPT conduit

Listings: Listings: Most valves are UL and CSA listed – consult factory.

Life Expectancy: Millions of cycles, depending on application, lubrication, etc.

Valve Weight: 0.60 lbs

Repair Packs: See table on proceeding page.

Options: Alternate Port Locations, Metering, Alternate Elastomers, All Stainless Steel Construction*

* Consult representative or factory for options and specifications.

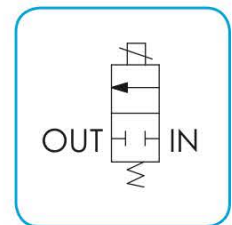
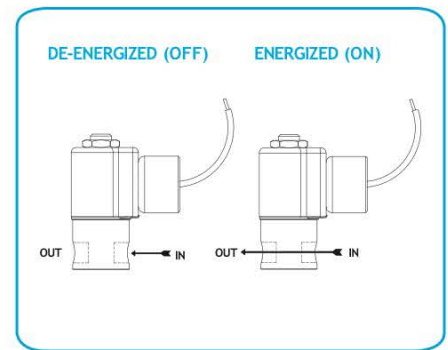

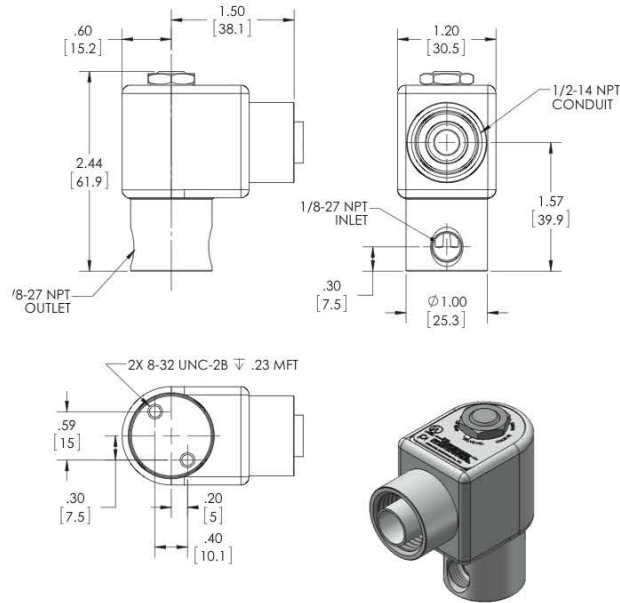

**SERIES 50 SLW
MODEL SLW52
2WNC
LOW WATTAGE**

VALVE SPECIFICATIONS

MAX. OPER. PRESS. DIFF.		MAX. OPER. PRESS. DIFF.		ORIFICE SIZE	CV FACTOR	VALVE NUMBER
GAS	LIQUID	GAS	LIQUID			
AC	DC	AC	DC	N.C.	N.C.	
600*	200	600	200	1/32	.022	SLW52G8DCCP
250	80	250	80	3/64	.055	SLW52H8DCCP
150	50	150	50	1/16	.075	SLW52J8DCCP
100	25	100	25	5/64	.134	SLW52V8DCCP
85	20	85	20	3/32	.156	SLW52K8DCCP
50		50		1/8	.230	SLW52N8DCCP
15		15		5/32	.292	SLW52O8DCCP

* FKM seals not recommended for pressure above 500 psi.

ORDERING INFORMATION:

WHEN ORDERING VALVES OR REPAIR PACKS ADD VOLTAGE AND FREQUENCY TO COMPLETE VALVE NUMBER. EXAMPLES: VALVE (SLW52J8DCCP 120/60) REPAIR PACK (KSLW52J AC)

WHEN ORDERING OPERATORS ADD THE LETTER "O" TO THE FRONT OF THE VALVE NUMBER, REPLACE BODY PORT NUMBER WITH THE LETTER "D": EXAMPLE: OPERATOR (QSLW52J8DCCP 120/60)